

Solid State Relays

Industrial, 1-Phase ZS (IO) w. LED and Built-in Varistor

Types RM 23, RM 40, RM 48, RM 60



- Zero switching (RM1A) or instant-on switching (RM1B) AC Solid State Relay
- Direct copper bonding (DCB) technology
- LED indication
- Built-in varistor 230, 400, 480, 600 V
- Clip-on IP 20 protection cover
- Self-lifting terminals
- Housing free of moulding mass
- 2 input ranges: 3-32* VDC and 20-280 VAC/22-48 VDC
- Operational ratings up to 100 AACrms and 600 VAC
- Non-repetitive voltage: Up to 1400 V_p
- Opto-insulation: > 4000 VACrms

Product Description

The industrial, 1-phase relay with antiparallel thyristor output is the most widely used industrial SSR due to its multiple application possibilities. The relay can be used for resistive, inductive and capacitive loads. The zero switching relay switches ON when the sinusoidal curve crosses zero and switches OFF when the current crosses zero. The instant-on relay

with DC control input can be used for phase control. The built-in varistor secures transient protection for the heavy industrial applications, and the LED indicates the status of the control input. The clip-on cover is securing touch protection to IP 20. Protected output terminals can handle cables up to 16 mm².

Ordering Key

RM 1 A 23 D 25

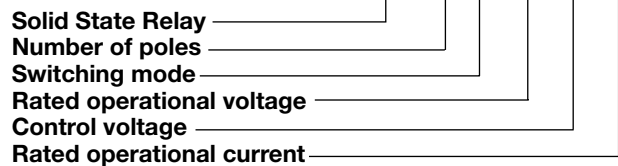

Type Selection

Switching mode	Rated operational voltage	Control voltage	Rated operational current
A: Zero Switching B: Instant-on switching	23: 230 VACrms 40: 400 VACrms 48: 480 VACrms 60: 600 VACrms	A: 20-280 VAC/22-48 VDC D: 3-32 VDC* <small>*4 to 32 VDC for 400, 480 and 600 VAC types</small>	25: 25 AACrms 50: 50 AACrms 75: 75 AACrms 100: 100 AACrms

Selection Guide

Rated operational voltage	Non-rep. voltage	Control voltage	Rated operational current			
			25 A	50 A	75 A	100 A
230 VACrms	650 V _p	3 - 32 VDC	RM1A23D25	RM1A23D50	RM1A23D75	RM1A23D100
		20 to 280 VAC 22 to 48 VDC	RM1A23A25	RM1A23A50	RM1A23A75	RM1A23A100
400 VACrms	850 V _p	3 - 32 VDC	RM1A40D25	RM1A40D50	RM1A40D75	RM1A40D100
		20 to 280 VAC 22 to 48 VDC	RM1A40A25	RM1A40A50	RM1A40A75	RM1A40A100
480 VACrms	1200 V _p	4 - 32 VDC	RM1A48D25	RM1A48D50	RM1A48D75	RM1A48D100
		20 to 280 VAC 22 to 48 VDC	RM1A48A25	RM1A48A50	RM1A48A75	RM1A48A100
600 VACrms	1400 V _p	4 - 32 VDC	RM1A60D25	RM1A60D50	RM1A60D75	RM1A60D100
		20 to 280 VAC 22 to 48 VDC	RM1A60A25	RM1A60A50	RM1A60A75	RM1A60A100

General Specifications

	RM1.23...	RM1.40...	RM1.48...	RM1.60...
Operational voltage range	24 to 265 VACrms	42 to 440 VACrms	42 to 530 VACrms	42 to 660 VACrms
Non-rep. peak voltage	≥ 650 V _p	≥ 850 V _p	≥ 1200 V _p	≥ 1400 V _p
Zero voltage turn-on	≤ 15 V	≤ 15 V	≤ 15 V	≤ 15 V
Operational frequency range	45 to 65 Hz	45 to 65 Hz	45 to 65 Hz	45 to 65 Hz
Power factor	> 0.5 @ 230 VACrms	> 0.5 @ 400 VACrms	> 0.5 @ 480 VACrms	> 0.5 @ 600 VACrms
Approvals*	UL, cUL, CSA	UL, cUL, CSA	UL, cUL, CSA	UL, cUL, CSA
CE-marking	Yes	Yes	Yes	Yes **

* CSA approval pending for RM1B

Input Specifications

	RM1...D..	RM1...A..
Control voltage range		
RM1.23., RM1.40.	3-32 VDC	20-280VAC, 22-48 VDC
RM1.48., RM1.60.	4-32 VDC	20-280VAC, 22-48 VDC
Pick-up voltage		
RM1.23., RM1.40.	≤ 2.75 VDC	≤ 22 VAC/DC
RM1.48., RM1.60.	≤ 3.75 VDC	≤ 22 VAC/DC
Reverse voltage	≤ 32 VDC	-
Drop out voltage	≥ 2 VDC	≥ 6 VAC/DC
Input current @ max input voltage		
RM1A	≤ 12 mA	≤ 5 mA
RM1B	≤ 15 mA	≤ 5 mA
Response time pick-up		
RM1A	≤ 1/2 cycle	≤ 1 cycle
RM1B	≤ 1 ms	≤ 6 ms
Response time drop-out	≤ 1/2 cycle	≤ 2 cycles

Output Specifications

	RM1....25	RM....50	RM1....75	RM1....100
Rated operational current				
AC51 @ Ta=25°C	25 Arms	50 Arms	75 Arms	100 Arms
AC53a @ Ta=25°C	5 Arms	15 Arms	20 Arms	30 Arms
Min. operational current	150 mA	150 mA	150 mA	150 mA
Rep. overload current t=1 s	< 55 AACrms	< 125 AACrms	< 150 AACrms	< 200 AACrms
Non-rep. surge current t=10 ms	250 A _p	600 A _p	1000 A _p	1500 A _p
Off-state leakage current @ rated voltage and frequency	< 3 mArms	< 3 mArms	< 3 mArms	< 3 mArms
I²t for fusing t=1-10 ms	< 310 A ² s	< 1800 A ² s	< 6600 A ² s	< 18000 A ² s
Critical di/dt	≥ 100 A/μs	≥ 100 A/μs	≥ 100 A/μs	≥ 100 A/μs
On-state voltage drop @ rated current	1.6 Vrms	1.6 Vrms	1.6 Vrms	1.6 Vrms
Critical dV/dt commutating	500 V/μs	500 V/μs	500 V/μs	500 V/μs
Critical dV/dt off-state min.	500 V/μs	500 V/μs	500 V/μs	500 V/μs

Thermal Specifications

	RM1....25	RM1....50	RM1....75	RM1....100
Operating temperature	-20° to 70°C	-20° to 70°C	-20° to 70°C	-20° to 70°C
Storage temperature	-40° to 100°C	-40° to 100°C	-40° to 100°C	-40° to 100°C
Junction temperature	≤ 125°C	≤ 125°C	≤ 125°C	≤ 125°C
R _{th} junction to case	≤ 0.80 K/W	≤ 0.50 K/W	≤ 0.20 K/W	≤ 0.20 K/W
R _{th} junction to ambient	≤ 20 K/W	≤ 20 K/W	≤ 20 K/W	≤ 15 K/W

Housing Specifications

Weight 25 A, 50 A 75 A, 100 A	Approx. 60 g Approx. 100 g
Housing material	Noryl GFN 1, black
Baseplate 25 A, 50 A 75 A, 100 A	Aluminium Copper, nickel-plated
Potting compound	None

Housing Specifications (Cont.)

Relay Mounting screws Mounting torque	M5 1.5-2.0 Nm
Control terminal Mounting screws Mounting torque	M3 x 9 0.5 Nm
Power terminal Mounting screws Mounting torque	M5 x 9 2.4 Nm

Functional Diagram

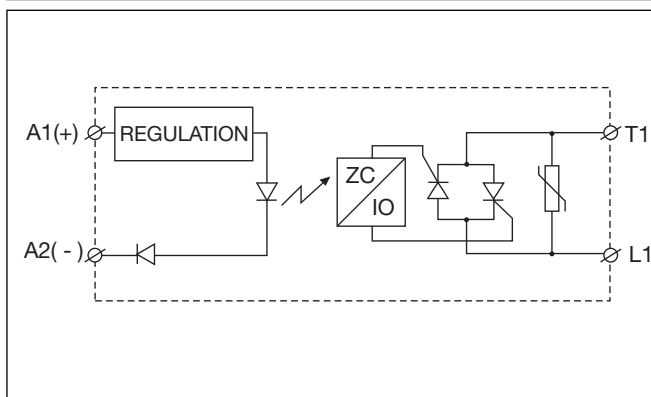

Dimensions

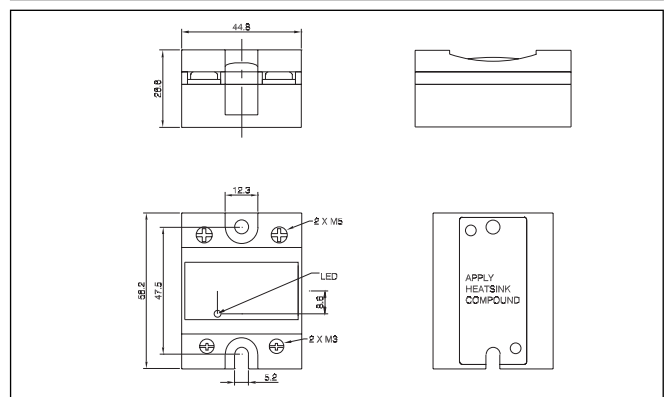

Heatsink Selection

Carlo Gavazzi Heatsink (see Accessories)	Thermal resistance...	...for power dissipation
No heatsink required	---	N/A
RHS 300	5.00 K/W	> 0 W
RHS 100	3.00 K/W	> 25 W
RHS 45A	2.70 K/W	> 60 W
RHS 45B	2.00 K/W	> 60 W
RHS 90	1.35 K/W	> 60 W
RHS 45A plus fan	1.25 K/W	> 0 W
RHS 45B plus fan	1.20 K/W	> 0 W
RHS 112	1.10 K/W	> 100 W
RHS 301	0.80 K/W	> 70 W
RHS 90 plus fan	0.45 K/W	> 0 W
RHS 112 plus fan	0.40 K/W	> 0 W
RHS 301 plus fan	0.25 K/W	> 0 W
Consult your distribution	> 0.25 K/W	N/A
Infinite heatsink - No solution	---	N/A

Insulation

Rated insulation voltage Input to output	≥ 4000 VACrms
Rated insulation voltage Output to case	≥ 4000 VACrms



Heatsink Dimensions (load current versus ambient temperature)

RM....25

Load current [A]	Thermal resistance [K/W]						Power dissipation [W]
	20	30	40	50	60	70	
25.0	2.70	2.34	1.98	1.61	1.25	0.89	28
22.5	3.10	2.69	2.28	1.86	1.45	1.04	24
20.0	3.61	3.13	2.65	2.18	1.70	1.23	21
17.5	4.26	3.70	3.14	2.59	2.03	1.47	18
15.0	5.14	4.47	3.80	3.14	2.47	1.80	15
12.5	6.38	5.56	4.73	3.91	3.09	2.27	12
10.0	8.25	7.19	6.14	5.08	4.02	2.97	9
7.5	11.4	9.94	8.49	7.04	5.59	4.14	7
5.0	17.7	15.4	13.2	11.0	8.74	6.51	4
2.5	-	-	-	-	18.2	13.6	2

T_A
Ambient temp. [°C]

RM....50

Load current [A]	Thermal resistance [K/W]						Power dissipation [W]
	20	30	40	50	60	70	
50.0	1.03	0.86	0.70	0.53	0.37	0.20	61
45.0	1.27	1.09	0.90	0.71	0.52	0.33	53
40.0	1.54	1.32	1.10	0.89	0.67	0.45	46
35.0	1.85	1.59	1.34	1.08	0.82	0.57	39
30.0	2.26	1.95	1.65	1.34	1.03	0.72	33
25.0	2.85	2.47	2.08	1.70	1.32	0.94	26
20.0	3.73	3.24	2.75	2.26	1.77	1.27	20
15.0	5.22	4.54	3.86	3.19	2.51	1.83	15
10.0	8.21	7.16	6.11	5.05	4.00	2.95	10
5.0	17.2	15.0	12.9	10.7	8.51	6.33	5

T_A
Ambient temp. [°C]

Junction to ambient thermal resistance, R _{th j-a}	< 20.0	K/W
Junction to case thermal resistance, R _{th j-c}	< 0.80	K/W
Case to heatsink thermal resistance, R _{th c-s}	< 0.20	K/W
Maximum allowable case temperature	100	deg.C
Maximum allowable junction temperature	125	deg.C

Junction to ambient thermal resistance, R _{th j-a}	< 20.0	K/W
Junction to case thermal resistance, R _{th j-c}	< 0.50	K/W
Case to heatsink thermal resistance, R _{th c-s}	< 0.20	K/W
Maximum allowable case temperature	100	deg.C
Maximum allowable junction temperature	125	deg.C

RM....75

Load current [A]	Thermal resistance [K/W]						Power dissipation [W]
	20	30	40	50	60	70	
75.0	0.91	0.78	0.65	0.52	0.39	0.26	77
67.5	1.10	0.96	0.81	0.66	0.51	0.36	68
60.0	1.34	1.17	1.00	0.83	0.66	0.49	59
52.5	1.60	1.40	1.20	1.00	0.80	0.60	50
45.0	1.93	1.68	1.44	1.20	0.96	0.72	42
37.5	2.38	2.08	1.78	1.49	1.19	0.89	34
30.0	3.06	2.68	2.30	1.91	1.53	1.15	26
22.5	4.21	3.68	3.16	2.63	2.10	1.58	19
15.0	6.51	5.70	4.88	4.07	3.26	2.44	12
7.5	13.5	11.77	10.09	8.41	6.73	5.04	6

T_A
Ambient temp. [°C]

RM....100

Load current [A]	Thermal resistance [K/W]						Power dissipation [W]
	20	30	40	50	60	70	
100.0	0.54	0.45	0.36	0.27	0.18	0.09	111
90.0	0.68	0.58	0.47	0.37	0.27	0.17	97
80.0	0.86	0.74	0.62	0.50	0.38	0.26	84
70.0	1.08	0.94	0.80	0.66	0.52	0.38	71
60.0	1.37	1.20	1.03	0.85	0.68	0.51	59
50.0	1.70	1.49	1.28	1.06	0.85	0.64	47
40.0	2.21	1.93	1.66	1.38	1.10	0.83	36
30.0	3.06	2.68	2.30	1.91	1.53	1.15	26
20.0	4.78	4.18	3.59	2.99	2.39	1.79	17
10.0	9.98	8.73	7.49	6.24	4.99	3.74	8

T_A
Ambient temp. [°C]

Junction to ambient thermal resistance, R _{th j-a}	< 20.0	K/W
Junction to case thermal resistance, R _{th j-c}	< 0.35	K/W
Case to heatsink thermal resistance, R _{th c-s}	< 0.10	K/W
Maximum allowable heatsink temperature	100	deg.C
Maximum allowable junction temperature	125	deg.C

Junction to ambient thermal resistance, R _{th j-a}	< 20.0	K/W
Junction to case thermal resistance, R _{th j-c}	< 0.30	K/W
Case to heatsink thermal resistance, R _{th c-s}	< 0.10	K/W
Maximum allowable heatsink temperature	100	deg.C
Maximum allowable junction temperature	125	deg.C

Fast-on terminals



- Fast-on tabs
- Type R..F.
- Screw mounted fast-on terminals
- Flat (0°) and angled (45°) orientation
- Input tab width: 4.8mm
- Output tab with: 6.3mm
- Tab dimensions according to DIN 46342 part 1
- Pure tin-plated brass

Ordering Key

RM1A48D50 F 4*

RS, RM Solid State Relay

Fast-on terminals

Tab orientation

* 0: Flat (0°)
4: Angled (45°)

Other Accessories

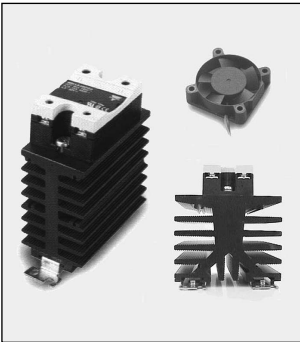

- Heatsinks and fans
- Type RHS....
- 0.25 to 5.00 k/W
- Single and dual relay types

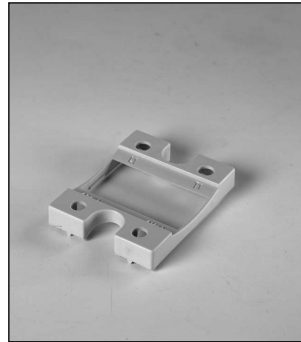

- Touch safety cover
- Type RMIP20
- IP20 protection degree
- Pack size: 20 pieces

All accessories can be ordered pre-assembled with Solid State Relays.
Other accessories include DIN rail adaptors, fuses, varistors and spacers.
For further information refer to Accessories datasheets.

Contact ThermX Southwest at 800-284-3767 for stock.
For solid state relay specific to your process or application,
call ThermX for quick turn around and competitively prices
for all quantities.