

# DM70 Hand-Held Dewpoint Meter for Spot-Checking Applications



*The Vaisala DRYCAP® Hand-Held Dewpoint Meter DM70 offers accurate and fast measurement for industrial dewpoint applications, such as compressed air, metal treatment and plastics drying.*

## Features/Benefits

- Designed for industrial spot checking and field calibration
- Three models: accurate measurement ranges from -60 to +60 °C (-76...+140 °F)
- Vaisala DRYCAP® Sensor with patented autocalibration function
- Low maintenance need due to superior long-term stability
- Sensor withstands condensation
- Fast response, enhanced by Sensor Purge option
- Easy-to-use user interface
- Data can be logged and transferred to a PC via MI70 Link software
- Compact, small and light
- NIST traceable (certificate included)

The Vaisala DRYCAP® Hand-Held Dewpoint Meter DM70 measures dewpoint temperature accurately over a wide measurement range. The probe may be inserted directly into pressurized processes, and it responds rapidly from ambient to process conditions. The sensor withstands condensation and fully recovers from getting wet.

### Three DMP74 probe models

Three probe models, all with auto-calibration, are available. The A and B models are both general purpose probes. The A model is for dewpoint range from -40 to +60 °C  $T_d$ , and the B model for -60 to +20 °C  $T_d$ . The C model is specifically developed for SF<sub>6</sub> gas with a dewpoint range down to -50 °C  $T_d$ .

The B and C probe models have an additional Sensor Purge feature. The Sensor Purge heats and dries the sensor, making the response from ambient to dry conditions exceptionally fast. This facilitates rapid spot checking measurements in low dewpoints.

### Low maintenance due to innovative autocalibration

The DM70 is fitted with the Vaisala DRYCAP® Sensor. The sensor provides reliable and high-performance dewpoint measurement with revolutionary long-term stability. The patented autocalibration procedure detects on-line possible measurement inaccuracies and automatically corrects dry-end drift in the calibration curve. These advanced features provide a long calibration interval and low maintenance cost.

The meter is calibrated in the factory against internationally traceable standards and delivered with a calibration certificate. The DM70 can also be sent to a Vaisala Service Center for a traceable recalibration.

### Easy-to-use user interface

The DM70 has a versatile and easy-to-use, menu-based user interface and a clear graphical LCD display with data-logger function. It can also be used as a tool for reading the output of fixed

Vaisala dewpoint transmitters, like the DMT242, DMT142 and DMP248.

### Various display variables

The DM70 displays one to three parameters at a time, either numerically or graphically. Several humidity units can be selected. In addition, the DM70 includes conversion from gas pressure dewpoint to ambient pressure dewpoint. An analog output is also available.

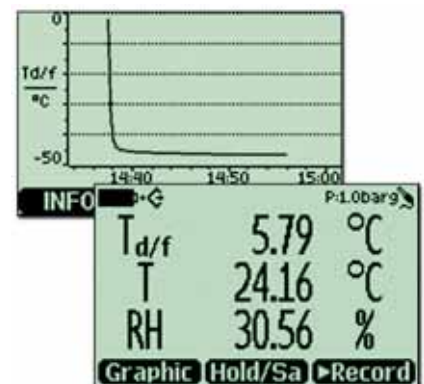

*The graphical display helps the user to know when the dewpoint plateau is reached.*

# Portable Sampling System and Sampling Cells

## MI70 Link PC connection

The DM70 has a MI70 Link Windows® software program for transferring logged and real time measurement data from the DM70 to a PC.

## Lightweight construction

The DM70 is small and rugged, and therefore an ideal choice for demanding applications. The long battery life provides convenient use in the field.

## DSS70A portable sampling system

The DSS70A is designed to provide dewpoint sampling flexibility. For processes at atmospheric pressure, a battery powered pump is used to extract a gas sample. For pressurized processes up to 20 bar, the sample is measured at process pressure and then reduced to atmospheric pressure for venting or re-direction, bypassing the pump. In all cases, the sample gas passes through a filter to remove particulate contamination before measurement. Flow through the system is controlled and monitored with a needle valve and flow meter.

The DSS70A is easily connected to an appropriate sample point with tubing (typically 1/4" or 6 mm). The measured dewpoint must be below ambient temperature to avoid condensation in the system. Gas temperatures higher than +40 °C (+104 °F) should be cooled with a short PTFE or stainless steel tube prior to entering the DSS70A.

## Sampling cells for pressurized processes

The DM70 can easily be connected to pressurized processes. In addition to direct pipeline installation, a variety of sampling cell options are available for gas sampling.

The DSC74 sampling cell is the recommended choice. It has a variety of connection adapters that allow several different ways of installation. The quick connector with a leak screw allows a very fast connection for compressed air lines. Additionally, two thread adapters are available for the inlet port.

The DSC74B is a two-pressure sampling cell, which enables measurements in both process and ambient pressure. This sampling cell is especially suitable for dewpoint measurements in SF<sub>6</sub> gas with the DMP74C probe.

The DMT242SC is a basic sampling cell. The DMT242SC2 is a sampling cell supplied with welded Swagelok connectors for sampling in a 1/4" pipeline.

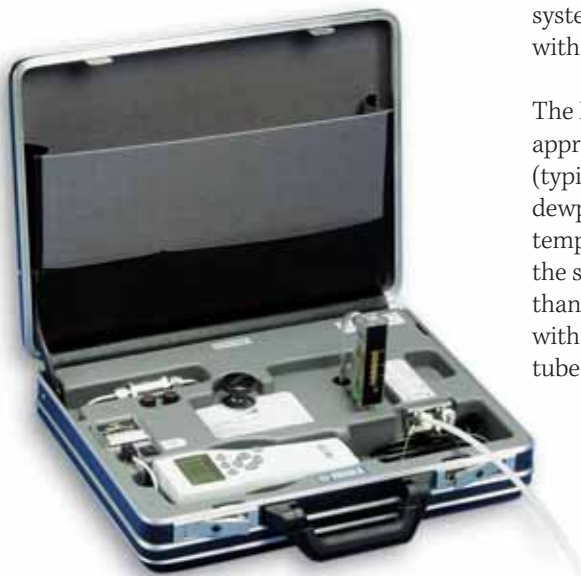

*The DSS70A provides a compact solution for field checking dewpoint where direct measurement is difficult. Typical applications for the sampling system are metal treatment and plastics drying processes.*

## DM70 Accessories

The DM70 meter is suitable for direct dewpoint measurements in the process in a wide temperature and pressure range. For more demanding applications, the DM70 can be used with the Vaisala sampling cell adapters, or with the Vaisala DRYCAP® Sampling System DSS70A.



*The sampling cells (from the left) DMT242SC2, DMT242SC and DSC74 can be used to connect the DM70 to sample gas flow. The DSC74B (right) is a two-pressure sampling cell that can be used for measurements in either pressurized or ambient pressure. The cooling/venting coil is an option for all sampling cells.*

# Technical Data

## DSS70A Sampling System and DSC74B/C Sampling Cells

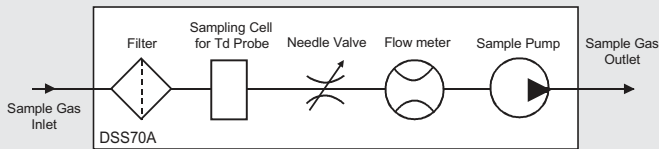

The DSS70A sampling system includes a filter to clean the dirty sample gas and a needle valve to control the sample flow rate with the flow meter. A sample pump is used to generate a sample flow from processes at ambient pressure.

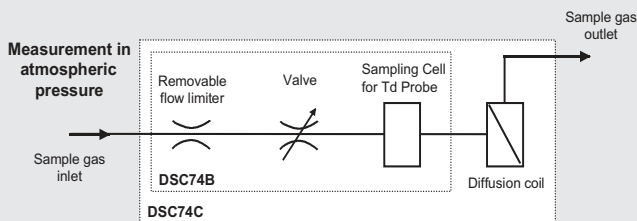
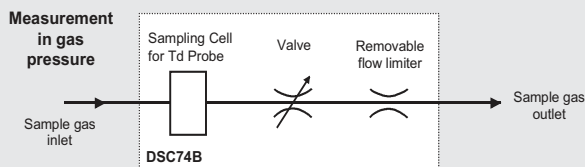

The DSC74B sampling cell enables the measurement of the sampled gas either in gas pressure up to 10 bar or in atmospheric pressure depending on the gas inlet and outlet. The DSC74C is like the DSC74B but with an additional coil to avoid back diffusion, the effect of surrounding moisture, in dewpoint measurements in atmospheric pressure.

## DM70 hand-held dewpoint meter (DMP74 probe + MI70 indicator)

### General

Battery operation time	continuous use	48 h typical at +20 °C (+68 °F)
	data logging use	up to 30 days
Housing materials		ABS/PC blend
Storage temperature		-40...+70 °C
Storage humidity		0...100 %RH non-condensing
Total weight		750 g

### Accessories

Connection cables for fixed Vaisala dewpoint transmitters	
for DMT242 transmitter	order no: 27160ZZ
for DMP248 transmitter	order no: 27159ZZ
for DMT142 transmitter	order no: 211917ZZ
Analog output cable	order no: 27168ZZ
Windows® software, includes PC connection cable	MI70LINK
10 m (32.81 ft) extension cable for probe	213017SP

## MI70 indicator

### Indicator general

Menu languages	English, French, German, Spanish, Swedish, Finnish
Display	LCD with backlight Graphic trend display of any parameter Character height up to 16 mm
Probe inputs	1 or 2
Power supply	Rechargeable NiMH battery pack with AC-POWER or 4xAA size alkalines, type IEC LR6
Analog output	0...1 VDC
Output resolution	0.6 mV
Data interface	RS232
Datalogging capacity	2700 points
Alarm	audible alarm function
Operating temperature range	-10...+40 °C (+14...+104 °F)
Operating humidity range	non-condensing
Housing classification	IP54
Weight	400 g

# Technical Data

## DMP74 dewpoint probes

### Measured variables, DMP74A probe

#### Dewpoint

Measurement range (typical) -50...+60 °C (-58...+140 °F)  
 Accuracy (A probe) -40...+60 °C ±2 °C (±3.6 °F)  
 (see graph below)

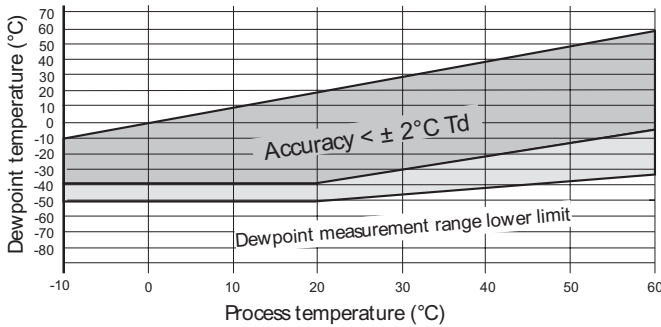

#### Response time

flow rate 0.2 m/s, 1 bar pressure, +20 °C (+68 °F) 63% [90%]  
 0 -> -40 °C  $T_d$  (32 -> -40 °F  $T_d$ ) 20 s [120 s]  
 -40 -> 0 °C  $T_d$  (-40 -> 32 °F  $T_d$ ) 10 s [20 s]

Dewpoint sensor Vaisala DRYCAP® 180S

#### Dewpoint converted to atmospheric pressure

Dewpoint range for converted  $T_d$  (20 bar to 1 bar)  
 with ±2 °C (±3.6 °F) accuracy -64...+60 °C (-83...+140 °F)

#### Temperature

Measurement range -10...+60 °C (+14...+140 °F)  
 Accuracy at +20 °C (+68 °F) ±0.2 °C (±0.36 °F)

#### Typical temperature dependence

of electronics ±0.005 °C/°C (±0.005 °F/°F)  
 Temperature sensor Pt100 IEC751 1/3 class B

#### ppm volume and ppm weight concentration

Measurement range (typical) 40...200 000 ppm  
 Accuracy at +20 °C (+68 °F) ±(7.3 ppm + 8.3% of reading)

#### Relative humidity

Measurement range 0...100 %RH  
 Accuracy at +20 °C (+68 °F)  
 RH < 5 % ±(0.025 %RH + 17.5% of reading)  
 RH > 5 % ±(0.8 %RH + 2% of reading)

### Measured variables, DMP74B and DMP74C (for SF<sub>6</sub> gas) probes

#### Dewpoint

Measurement range (typical) -70...+30 °C (-94...+86 °F)  
 Accuracy (B and C probe) -60...+20 °C ±2 °C (±3.6 °F)  
 (see graph below)

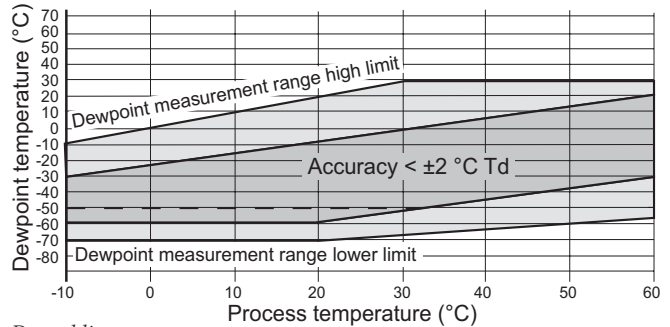

#### Dotted line:

For DMP74C the ±2 °C accuracy range is limited to -50 °C  $T_d$  when used in SF<sub>6</sub> gas.

#### Response time

flow rate 0.2 m/s, 1 bar pressure, +20 °C (+68 °F) 63% [90%]  
 0 -> -60 °C  $T_d$  (32 -> -76 °F  $T_d$ ) 50 s [340 s]  
 -60 -> 0 °C  $T_d$  (-76 -> 32 °F  $T_d$ ) 10 s [20 s]

Dewpoint sensor Vaisala DRYCAP® 180M

#### Dewpoint converted to atmospheric pressure

Dewpoint range for converted  $T_d$  (20 bar to 1 bar)  
 with ±2 °C (±3.6 °F) accuracy -80...+20 °C (-112...+68 °F)

#### Temperature

Measurement range -10...+60 °C (+14...+140 °F)  
 Accuracy at +20 °C (+68 °F) ±0.2 °C (±0.36 °F)

#### Typical temperature dependence

of electronics ±0.005 °C/°C (±0.005 °F/°F)  
 Temperature sensor Pt100 IEC751 1/3 class B

#### ppm volume and ppm weight concentration

Measurement range (typical) 2...40 000 ppm  
 Accuracy at +20 °C (+68 °F)  
 < 40 ppm ±(0.5 ppm + 25.4% of reading)  
 > 40 ppm ±(7.3 ppm + 8.3% of reading)

### Measurement environment, all probe models

Temperature -10...+60 °C (+14...+140 °F)  
 Pressure  
 DMP74A 0...20 bar<sub>a</sub> (0...290 psia)  
 DMP74B 0...20 bar<sub>a</sub> (0...290 psia)  
 DMP74C 0...10 bar<sub>a</sub> (0...150 psia)  
 Sample flow rate no effect for measurement accuracy

### General, all probe models

Measured gases non-corrosive gases  
 Probe material (wetted parts) Stainless steel (AISI 316L)  
 Sensor protection Sintered filter (AISI 316L)  
 partno: HM47280  
 Mechanical connection G1/2" ISO228-1 thread  
 with bonded seal ring (U-seal)  
 Housing classification IP65 (NEMA 4)  
 Weight 350 g

Distributor: ThermX Southwest  
 For Price and Availability Call: 1-800-284-3769

# Technical Data and Dimensions

## Sampling cells technical data

DSC74	sampling cell for pressurized gases
pressure limit	1 MPa (10 bar <sub>g</sub> , 145 psig)
DSC74B	two pressure sampling cell
pressure limit	1 MPa (10 bar <sub>g</sub> , 145 psig)
DSC74C	DSC74B with DMCOIL cooling/venting coil
DMCOIL	cooling/venting coil
DMT242SC	sampling cell
pressure limit	10 MPa (100 bar <sub>g</sub> , 1450 psig)
DMT242SC2	sampling cell with Swagelok connectors
pressure limit	4 MPa (40 bar <sub>g</sub> , 580 psig)
Material for all sampling cells	stainless steel AISI316

## DSS70A sampling system

### Operating conditions

Operating gases	air, N <sub>2</sub> and other non-toxic, inert gases
Dewpoint range	-60 °C...T <sub>amb</sub> (-76 °F...T <sub>amb</sub> )
Inlet/outlet connection	1/4" SWAGELOK
Operating temperature	
ambient temperature	0...+40 °C (32...+104 °F)
process gas temperature	
with PTFE tube at +20 °C (+68 °F)	max. +200 °C (+392 °F)
with stainless steel tube	specification according to stainless steel tube specification
maximum gas temperature at inlet	+40 °C (+104 °F)
Operating pressure	
with pump	0.6...1.2 bar <sub>a</sub> (8.7...17.4 psia)
pump disconnected	0...20 bar <sub>a</sub> (0...290 psia)

## General

Battery operation time for pump	8 h continuous use
	battery can be recharged using DM70 charger
Filter	7 mm inline filter cartridge 1/4" SWAGELOK SS-4F-7 (spare part order no. 210801)
Materials	
wetted parts	Stainless steel
carrying case	ABS plastic
Case size (W x D x H)	430 x 330 x 100 mm
Weight	5.5 kg (12 lbs)

## Electromagnetic compatibility

Complies with the EMC standard EN61326-1:1997 + Am1:1998 + Am2:2001; Generic Environment.

## Dimensions

Dimensions in mm (inches).

DSC74, same as the body of DMT242SC and DMT242SC2.

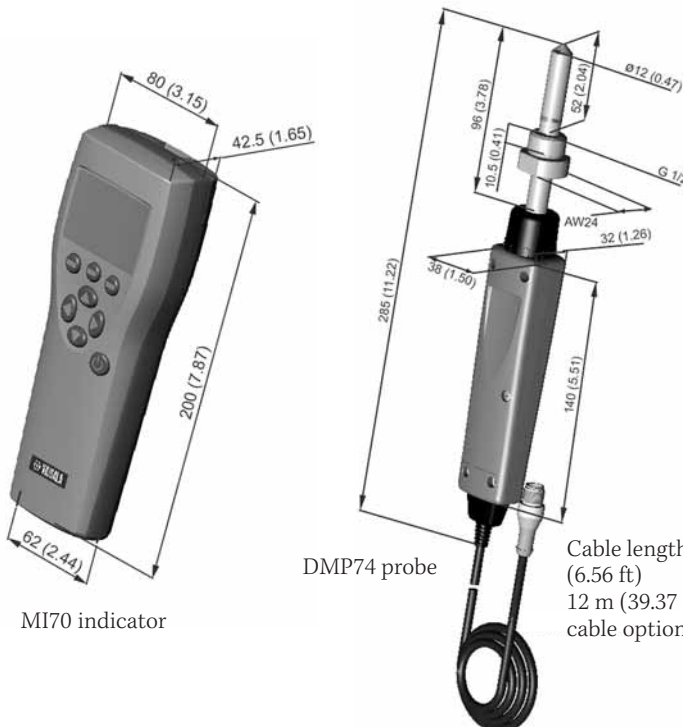
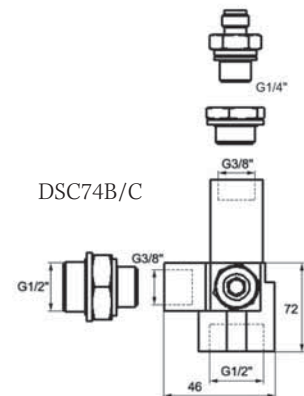
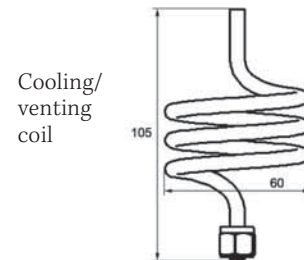
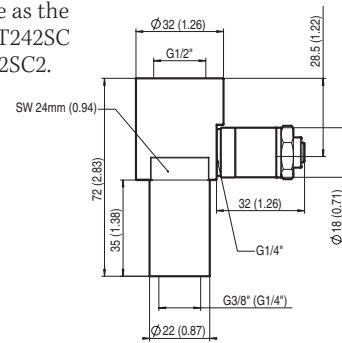

Cable length 2 m (6.56 ft)  
12 m (39.37 ft)  
cable optional

DRYCAP® is a registered trademark of Vaisala.  
Specifications subject to change without prior notice.  
© Vaisala Oyj



# Dry without a Doubt

*Excess moisture in compressed air can cause many problems both to the end product and to the components in the air distribution system itself. The DM70 can be used for spot measurements at the compressed air line or for field checks of other dewpoint transmitters. Photo: Atlas Copco*



*To ensure the best quality and yield of end products plastics must be sufficiently dry before further processing. The DM70 provides an easy method for checking the plastic dryer performance.*

*Dewpoint is an important parameter in moisture measurement and control of SF<sub>6</sub> gas insulated equipment, such as high voltage switchgear. The DM70 is an easy and fast hand-held instrument for dewpoint measurement with direct sampling. Photo: Areva T&D*

