



12 Inch 1 & 2 Pen Recorder/Controller

DESCRIPTION

The MRC 8000 incorporates numerous refinements over its 10" MRC 7000™ sibling, including a larger 12 inch recording area; an advanced platen assembly which eliminates slide wire feedback for improved reliability; as well as the incorporation of optional isolated 4–20mA outputs to provide the highest resolution and accuracy available in a recorder of this type.

The MRC 8000 is offered in two versions: a basic recorder and a recording controller. Both may be specified as either single pen or dual pen units. Each version is capable of measuring, recording and displaying temperature, pressure, level, flow and other process variables. The MRC 8000 includes isolated universal inputs and a list of optional capabilities including: transmitter power supply, 5A relay outputs, auxiliary inputs for remote setpoints, RS-485 communications, door lock and NEMA 4X enclosure.

MRC 8000™

*Rugged, Reliable and Refined
12 Inch Diameter Recording for
Larger Recording Areas!*

APPLICATIONS:

- Process Validation
- Trend Analysis
- Regulatory Compliance
- Product Safety:
 - Temperature
 - Pressure
 - pH Level
 - Flow

INDUSTRIES

Oven, chamber, furnaces, heat treating, food processing, harsh water environments

FEATURES/BENEFITS

- 12" Micro-based recording controller with remote setpoint capability
- Two large displays—allow you to see critical process values at the same time on 2 pen models
- Easy, straightforward programming—allows you to configure your recorder with a logical step-by-step process using a simple keypad
- High resolution of recorder process variables for better record accuracy
- Reliability—maintenance free recording for years to come

MRC 8000™

**Rugged, Reliable and Refined
12 Inch Diameter Recording for Larger
Recording Areas!**

12 Inch 1 & 2 Pen Recorder/Controller

SPECIFICATIONS

STANDARD FEATURES

Modes: Digital; record or controller functionality.

Display: Two 4-digit digital displays: 0.56" high, red, seven segment LED; 3 button keypad; automatic and decimal point positioning.

Status Indicators: Red LEDs for ALRM1/ALRM2 (Recorders); yellow, red LEDs MAN, OUT1/OUT2, ALRM.

Chart: 10" circular chart; 100 charts furnished with each instrument. Unless otherwise specified, charts shipped with instrument are 0–100 range. 24 hour rotation default setting.

Chart Drive: DC Stepper Motor.

Chart Rotation: User configurable from 0.1 and 999.9 hours per revolution.

Chart Range: Bottom and top of span –9999 to 9999 units.

Pen Type: One or two disposable fiber tip pen.

Pen Color: Pen 1 (red); Pen 2 (green).

Memory Backup: Battery backed SRAM; 5 year minimum life.

Construction/Enclosure: Gasketed cover, case and windows. Structural foam case and cover with plastic or glass window area.

OPERATING CHARACTERISTICS

Operating Temp: 32° to 122°F (0° to 50°C).

Storage Temp: –40° to 149°F (–40° to 65°C).

Humidity: 0% to 90% non-condensing R.H.

Vibration: 0.5 to 100Hz @ 0.2g.

ELECTRICAL

Power Consumption: 25VA max.

Line Voltage: 115V or 230VAC ±10%, 50–60Hz.

INPUTS

Thermocouple: J, K, T, R, S, E, B, N, C.

RTD: 100 ohm, platinum; 0.00385 ohms/ohm/°C

RTD Excitation Current: 330 microamps, typical.

DC Voltage: 0–25mV, 0–50mV, 10–50mV, 0–5V, 1–5V.

DC Current: 4–20mA or 0–20mA used with appropriate external shunt resistor.

Remote Setpoint Input: 0–5VDC, 1–5VDC, 4–20mA, or 0–20mA with shunt resistor.

OUTPUTS

CONTROL OUTPUTS:

ON/OFF: Assignable to alarm and control outputs.

Relay: SPDT; 115VAC 5.0A resistive, 1/8HP, 230VAC, 230VAC 2.5A resistive, 1/8HP, 250VA.

SSR Driver: Open collector output; short circuit protected @ 100mA max; provides 4VDC @ 20mA or 3VDC @ 40mA.

Current: Assignable to process value or setpoint transmission or control outputs; 0–20mA or 4–20mA nominal output span; 650 ohm

ALARM/EVENT OUTPUTS (Options):

Number: Up to two process alarms for each of two inputs. Type: Process high/low (recorder); process, deviation and band (controller).

Relay: SPDT; 115VAC 5.0A resistive, 1/8HP, 230VAC; 230VAC 2.5A resistive, 1/8HP, 250VA.

SSR Driver: Open collector output; short circuit protected @ 100mA max; provides 4VDC @ 20mA or 3VDC @ 40mA.

Process Alarm: Direct (High) or Reverse (Low) –9999 to 9999 units.

Deviation Alarm: Direct (deviation above setpoint) or Reverse (deviation below setpoint) –3000 to 3000 units.

Deviation Band Alarm: Open or closed 1 to 3000 units.

Alarm Hysteresis: 0–300 units.

PERFORMANCE

GENERAL:

Input Measurement Error: Type J, K, T, E, N, C, T/C and RTD ±0.25% of reading plus 1 degree @ 25°C; Type R, S, B, C, T/C

Ambient Temperature Error: 0.04% of span per degree C deviation from 25°C.

Cold Junction Compensation Error: ±0.2% @ 25°C.

Cold Junction Compensation Rejection: 0.04% deviation from 25°C.

Linearization Error: TCs: ±0.25°C typical; ±0.5°C worst case with exceptions; RTDs: ±0.1°C typical; ±0.3°C worst case.

Noise Rejection: Common Mode Rejection: 90dB minimum; 24VAC maximum for RTD input; 115VAC max for other inputs; Normal Mode Rejection: 85dB minimum @ 60Hz or greater.

Isolation: N/A.

Chart Accuracy: Recording: 0.5% of span.

Chart Rotation: ±0.5% or rotation time..

Chart Accuracy: Recording: 0.5% of span.

Chart Rotation: ±0.5% or rotation time.

Resolution: 0.15% of chart span.

Dead Band: 0.3% of chart span.

Process Value Output Limit: N/A.

Record Error Limit: N/A.

CONTROL PARAMETERS:

Proportional Band Output 1/Output 2: 1 to 3000 units.

Manual Reset (Integral): –1500 to 1500 units.

Auto Reset (Integral): 0–100 repeats/minute.

Rate Derivative: 0–10 minutes.

Cycle Time Output 1/Output 2: 1–240 seconds.

Position Proportioning Sensitivity: 0.0–50.0%.

ON/OFF Hysteresis: 0–300 units (width of hysteresis band).

First /Second Output Position: –1000 to 1000 units.

Control Action: Direct or reverse.

Automatic Transfer Function: User-selectable to transfer from manual to automatic control when setpoint is reached; can be disabled.

Anti-Reset Windup: Auto-reset is disabled when the process is outside of the proportional band.

Auto/Manual: Bumpless transfer.

Manual Output: 0–100%.

Output Limiting: High/Low 0–100%.

Setpoint Limiting: High/Low limit: –9999 to 9999 units.





PARTLOW™ brand

Flow Controller

MMRC 8000'

*Rugged, Reliable and Refined
12 Inch Diameter Recording for
Larger Recording Areas!*

MODELS

Code 1: Model	Code 2: Pen 1	Code 3: Pen 2	Code 4: Relay (SPST) Outputs*	Code 5: SSR Driver Outputs*	Code 6: 4-20mA Outputs	Code 7: Transmitter Power Supply	Code 8: Pen 1 Aux. Input	Code 9: Pen 2 Aux. Input	Code 10: Digital Communications	Code 11: Enclosure Options	Code 12: Operating Voltage	Code 13: Option Suffix
8	<input type="checkbox"/>	<input type="checkbox"/>	<input type="checkbox"/>	<input type="checkbox"/>	<input type="checkbox"/>	<input type="checkbox"/>	<input type="checkbox"/>	<input type="checkbox"/>	<input type="checkbox"/>	<input type="checkbox"/>	<input type="checkbox"/>	0 0
MRC8000 12 Inch Chart Recorder / Controller	1 Recorder Only 2 Recording Controller	0 None 1 Recorder Only 2 Recording Controller	0 None 1 One SPST 2 Two SPST 4 Four SPST	0 None 1 One 2 Two 4 Four	0 None 1 One 2 Two	0 None 1 24VDC Regulated /Isolated	0 None 1 Position Proportioning 2 Remote Setpoint	0 None 1 Position Proportioning 2 Remote Setpoint	0 None 2 RS-485 Total Access	1 Glass Window NEMA 3 2 Glass Window NEMA 4X 3 Glass Window NEMA 3 w/Door Lock 4 Plastic Window NEMA 3 5 Plastic Window NEMA 4X 6 Plastic Window NEMA 3 w/Door Lock	1 115VAC 2 115/230VAC With CE 4 115VAC 5 115/230VAC	

Made in USA.

* The total quantity of SPST Relays and SSR Drivers must be less than or equal to four.

NOTE: 4-20mA inputs are accommodated using the 1-5V input and a 250 ohm Shunt Resistor, P/N 64411701 or the 10-50mA input and a 2.5 ohm Shunt Resistor, P/N 64411702. The 250 ohm resistor is included for each input.

* Specifications subject to change without notice in accordance with our DBS policy of continuous improvement. All product and brand names are trademarks of their respective companies. All rights reserved.

Partlow® brand and MRC 8000® are trademarks of Danaher Industrial Controls Group. All rights reserved.

© 2005 DICG Corp.
Partlow Brand MRC 8000 Data Sheet (5/05)

Made in USA.

* Specifications subject to change without notice in accordance with our DBS policy of continuous improvement. All product and brand names are trademarks of their respective companies. All rights reserved.

Partlow® brand and MRC 8000® are trademarks of Danaher Industrial Controls Group. All rights reserved.

© 2005 DICG Corp.
Partlow Brand MRC 8000 Data Sheet (5/05)

Recorders

PARTLOW™ brand

MRC 8000™

*Rugged, Reliable and Refined
12 Inch Diameter Recording for Larger
Recording Areas!*

12 Inch 1 & 2 Pen Recorder/Controller

SPECIFICATIONS

COMMUNICATIONS INTERFACES	PROTECTION	OPTIONS/ACCESSORIES
<p>Communications Port: RS-485 serial, half duplex.</p> <p>Protocol: Per ASCII and ANSI X3.28 subcategories 2.5 & A4.</p> <p>Bit Rate: User configurable; 300, 600, 1200, 2400, 4800 or 9600/sec.</p> <p>Configuration: Monitor: Read only. Normal: Read and write.</p>	<p>NEMA 3 standard; NEMA 4 optional; CE compliance optional.</p>	<p>Plastic or glass window option.</p> <p>24V DC transmitter power supply option.</p> <p>Door lock option.</p> <p>NEMA 4 protection option; CE compliance option.</p> <p>5A relay output option.</p> <p>Remote setpoint/position proportioning option.</p> <p>RS-485 communication option.</p> <p>115 or 230VAC input option.</p> <p>Door lock and sealed conduit/connector option.</p>
RATINGS/AGENCY APPROVALS	PHYSICAL DIMENSIONS	WARRANTY
<p>Safety: UL 1092/916 and QUXY File E67237; CSA Spec 142 File E67237; CE EN60010-1 1993/1995.</p> <p>Immunity: CE EN50082-1:1992</p> <p>Emissions: CE EN55022:1987 Class A.</p> <p>Limit Device: N/A</p> <p>Other: ISO 9002 registered.</p>	<p>Width: 14.12" (359mm).</p> <p>Depth: 7.75" (197mm).</p> <p>Height: 16.77" (426mm).</p> <p>Weight: 20 lbs (9.1kg).</p> <p>Mounting/Mounting Position: Panel or wall.</p>	<p>3 years.</p>

DIMENSIONS

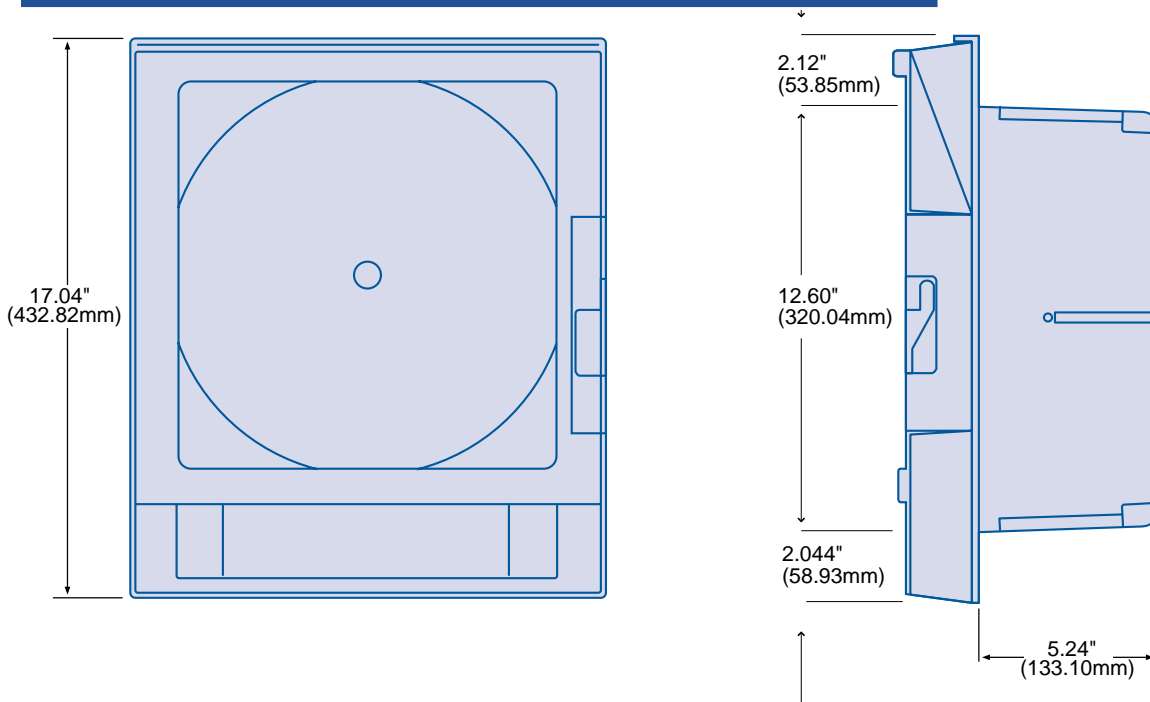

Partlow MRC 8000 Chart Recorder / Controller
ThermX Southwest 800-284-3769
www.thermx.com