

# PMP 4000

## PMP 4000 Series

Amplified Output Pressure Transducers



- $\pm 0.04\%$  accuracy
- 400% overpressure
- 0.1% stability per annum
- Ranges from 1 to 10,000 PSI
- Available 3-4 weeks ARO



# PMP 4000 Series

## Amplified Output Pressure Transducers

**For over 25 years Druck has manufactured precision pressure sensors with a capability to meet critical applications in industrial, aerospace and research environments.**

The PMP 4000 series is the latest complete range of high level output pressure transducers offering new levels of measurement accuracy, stability and flexibility from a standard production device.

At the heart of the 4000 Series is an advanced, high stability pressure measurement element micro-machined from single crystal silicon within Druck's own Class 100 processing facility. The silicon element is mounted within a high integrity glass-to-metal seal and is fully isolated from the pressure media by a Hastelloy isolation diaphragm, electron beam welded to the front of the glass-to-metal seal.

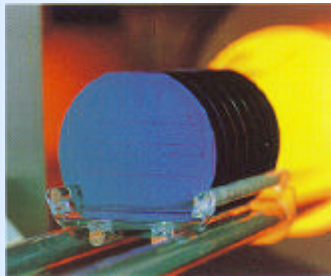

*Silicon wafers being loaded into an oxidation furnace.*

Surface mount electronics condition the output from the silicon diaphragm, correct for thermal induced errors and configure the output to the required high level voltage. Advanced design features built into the electronic circuitry enables minimum sensor size with utmost reliability. The electronics incorporate power supply regulation, reverse polarity, over-voltage and short circuit protection, coupled with EMC protection components.

The fully encapsulated solid state design ensures integrity of product under high levels of shock and vibration, with an ingress protection rating of NEMA 4X, dependent upon the electrical termination selected.

Every sensor is fully tested over both pressure and temperature ranges to demonstrate compliance to the specification. Prior to shipping, the sensor is adjusted to meet the particular pressure range and units, configured to the desired high level output voltage and completed with a range of electrical connections.

The demountable electrical connection formats allow the user to access the zero and span trim controls for system interchangeability and ease of re-calibration. A range of stainless steel pressure connections interface the sensor to the process media.

The PMP 4000 Series from Druck is ideally suited to meet the demands of the industrial, automotive and aerospace test cell markets. New levels of performance measurement ( $\pm 0.04\%$ ) coupled with excellent stability negates the need for regular re-calibration periods, thus significantly reducing the cost of ownership.

Test applications include R&D, road test, engine test, flying testbed, environmental test and many others where accuracy, stability and durability are of paramount importance.

A combination of

- High Accuracy
- High Overload
- Excellent Stability
- Fast Dynamic Response

make the Druck PMP 4000 Series a world leader in the industrial and automotive test market.

With the benefit of the latest silicon measurement technology, the PMP 4000 Series can withstand the most demanding applications and still provide the performance of a precision pressure measurement instrument.



*Computerized testing and calibration of pressure transducers.*



*Automotive engine shown on a research and development test bed.*



## Standard Specification

### Operating Pressure Range

Any zero based span available between 1 psi and 10,000 psi gauge and absolute. Limited to 500 psi for differential formats.

### PMP 4000

1, 2.5 psi gauge  
5, 10, 15, 20, 25, 30, 50, 100, 150, 200, 300, 500 psi gauge or absolute  
1000, 2000, 3000, 5000, 7500, 10000 psi sealed gauge or absolute  
11.5 to 17.5 psia (Barometric Range)

### PMP 4100

1, 2.5, 5, 10, 15, 20, 25, 30, 50, 75, 100, 150, 200, 300, 500 psi differential

Intermediate ranges, compound ranges (e.g., -15 to + 30 psig), bi-directional differential ranges, and other pressure units may be specified

For pressure ranges down to  $\pm 0.04$  inches H<sub>2</sub>O refer to the LP Series data sheets

### Over Pressure

#### Gauge and Absolute

- 10 x for ranges 1 and 2.5 psi
- 6 x for range 5 psi
- 4 x for ranges 10 to 900 psi to a maximum of 2000 psig
- 2 x for ranges 1000 to 10,000 psi to a maximum of 15,000 psig

#### Differential

##### Positive (Hi) side:-

- 10 x for ranges 1 and 2.5 psi
- 6 x for range 5 psi
- 4 x for ranges 10 to 300 psi
- 3 x for range 500 psi

##### Negative side:-

Must not exceed positive side by greater than:-

- 6 x for ranges 1 and 2.5 psi
- 4 x for range 5 psi
- 150 psi for ranges 150 to 500 psi

### Line Pressure

1000 psig maximum

### Positive Pressure Media

Fluids compatible with stainless steel 316L and Hastelloy C276.

### Excitation Voltage

For all ranges below 10 psi, 15 to 32 Vdc

### Output Voltage

0 to 5 Vd.c. 3 wire

*Alternative 3 wire outputs can be specified.*

e.g. 1 to 5 V, 0 to 10 V, -5 to + 5 V etc.

Maximum offset voltage is 2.5V.

Maximum full scale voltage is 10 V with

15 V minimum supply.

Bi-directional outputs available.

### Output Impedance

< 20  $\Omega$ .

### Load Impedance

Greater than 10 K $\Omega$  for quoted performance.

### Shunt Calibration

Connecting an external link between the appropriate terminals results in a positive shift of 80% FSO. Other values are available - refer to Druck.

*Not available for PMP 4070 and PMP 4170*

### Combined Non-linearity, Hysteresis and Repeatability

Standard:  $\pm 0.08\%$  F.S. BSL

Option A:  $\pm 0.04\%$  F.S. BSL.

### Zero Offset and Span Setting

$\pm 5\%$  site adjustable by sealed, non-interacting potentiometers. Demountable electrical connections only.

### Stability

0.1% F.S./annum

For ranges below 5 psi this value may increase.

### Operating Temperature Range

-40<sup>o</sup> to +180<sup>o</sup>F

*This temperature range can be extended.*

### Temperature Effects

Standard:

- $\pm 1\%$  FS TEB for range 32 to +122<sup>o</sup>F
- $\pm 2\%$  FS TEB for range -5 to +180<sup>o</sup>F

Option A:

- $\pm 0.5\%$  FS TEB for range 32 to +122<sup>o</sup>F
- $\pm 1\%$  FS TEB for range -5 to +180<sup>o</sup>F

For ranges below 5 psi, these values may increase.

*Improved specification available - refer to Druck.*

### Acceleration Sensitivity

Typically 0.02% F.S./g for 5 psi range decreasing to 0.0003% F.S./g for ranges above 900 psi, along the sensitive axis.

### Mechanical Shock

1000g, 1ms half sine pulse in each of 3 mutually perpendicular axes will not affect performance.

### Vibration

Response less than 0.05% F.S./g at 30g peak 10Hz-2kHz, limited by 12mm double amplitude. (MIL-STD 810C Proc 514.2-2 Curve L)

### Weight

- 4 oz Nominal for ranges 1 psi to 900 psi
- 6 oz Nominal for ranges 1000 to 10,000 psi
- 7 oz Nominal for differential ranges.

### Electrical Connection

A wide range of cable and connector versions are available. Some electrical options are demountable to allow access to zero and span potentiometers.

*See installation drawings and ordering information for details.*

### Pressure Connection

1/4" NPT Female

1/4" NPT Male

MS 33656-4 Fitting (1/4 AN).

*Others available on request;*

*Note: For ranges 7,500 and 10,000 psi, high pressure fittings are recommended by Druck.*

## Ordering Information

Please state the following:

- (1) Select model number

### Code Base Model Number

PMP40XX Gauge or absolute

PMP41XX Differential

### Code Electrical Connection

00 Core

10 Fixed cable

15 Demountable cable

20 Cable gland

30 Submersible

50 Fixed male conduit

60 Fixed 6 pin bayonet connector

65 Demountable 6 pin bayonet connector

70 DIN plug/socket

80 Fixed Hi-rose connector

85 Demountable Hi-rose connector

90 WK6-32S connector

### PMP4070 Typical model number

- (2) Pressure range and units
- (3) Gauge or absolute (PMP 4000 only)
- (4) Combined non-linearity, hysteresis and repeatability  
State Option A (if required).
- (6) Output voltage at zero pressure
- (7) Output voltage at full scale pressure
- (8) Pressure connection required

### Accessories

Mating connector

DPI 280 Digital Indicator

DPI 145 Precision Indicator

LDI 1001 Local Display (4070/4170 only)

*For non-standard requirements - refer to Druck.*

### Calibration Standards

Instruments manufactured by Druck are calibrated against precision pressure calibration equipment which is traceable to NIST.



Druck is an ISO 9001 registered company.

*Continuing development sometimes necessitates specification changes without notice.*

# PMP 4000 Series

## Amplified Output Pressure Transducers



Installation Drawings - dimensions in inches.

A full range of alternative cable and connector versions are available - refer to Druck for further information and detailed installation drawings.

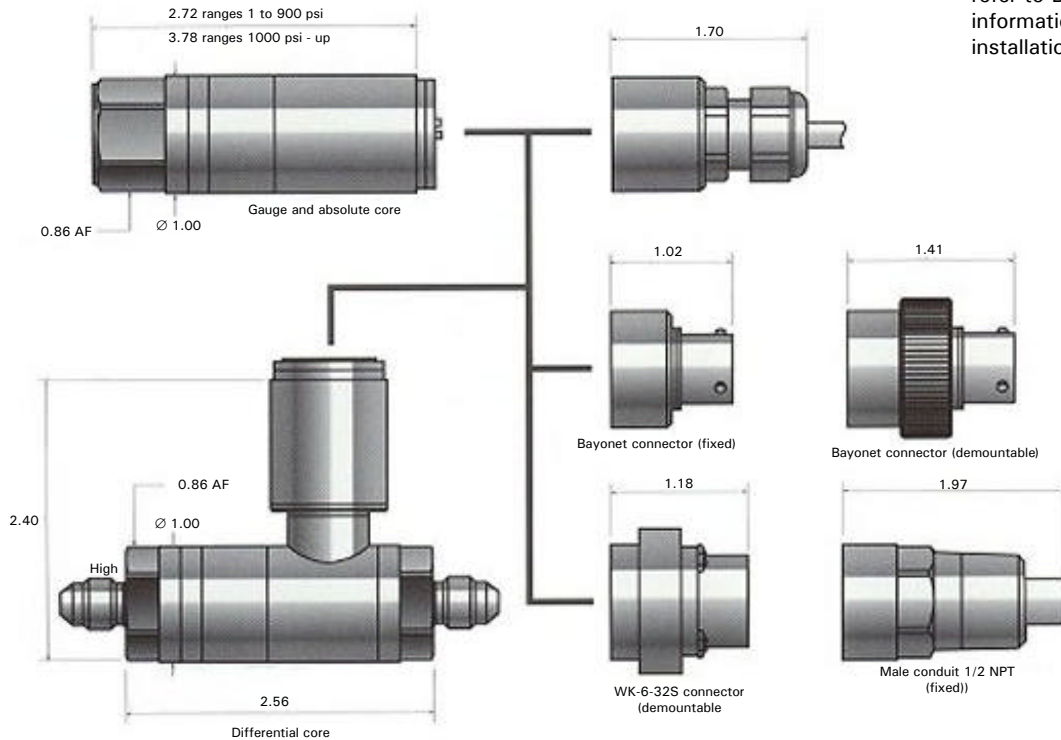

## Associated Products



Left: DPI 610 Field Portable Pressure Calibrator  
Centre: TRX-II Portable Documenting Calibrator  
Right: DPI 605 Precision Portable Pressure Calibrator  
Inset: LP Series of Low Pressure Sensors

Druck manufactures a comprehensive range of pressure instrumentation to complement the PMP 4000 Series.

Portable pressure, temperature and electrical field calibrators allow for local calibration reducing plant down time while maintaining the quality requirements of ISO 9000. In addition, the Druck range of calibration equipment is completed by primary standard deadweight testers.

The LP Series provides full scale absolute ranges as low as 0.03 psia and differential ranges as low as  $\pm 0.04$  inches H<sub>2</sub>O wet/wet differential pressure.

For further information and product data sheets - refer to Druck.

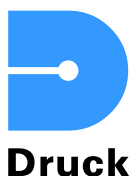

Druck Incorporated  
4 Dunham Drive  
New Fairfield, CT 06812

GE Druck PMP 4000 Pressure Transducer  
Distributor: ThermX Southwest 800-284-3769  
[www.thermx.com](http://www.thermx.com)