

PDCR 4000

PDCR 4000 Series



High Performance Millivolt Output Pressure Transducers

- $\pm 0.04\%$ FS accuracy
- ranges from 1psi to 10,000 psi
- Gauge, absolute & differential
- $\pm 0.1\%$ Stability per annum
- 400% Overpressure
- Hastelloy & stainless wetted parts



PDCR 4000 Series

High Performance Millivolt Output Pressure Transducers

The Druck PDCR 4000 Series, a range of high performance millivolt output pressure transducers, is a continuation of a successful family of products started in the early 1970's. This new generation of transducers offers enhanced levels of measurement accuracy, stability and reliability with a flexible specification to meet the varied and demanding needs of today's industrial and OEM users.

At the heart of each transducer are the latest advances in micro-machined silicon diaphragm technology from Druck's own class 100 silicon processing facility. The pressure sensitive silicon element is mounted within a high integrity glass-to-metal seal and is fully isolated from the pressure media by a Hastelloy isolation diaphragm, which is electron beam welded in front of the seal.

Packaged with conditioning electronics into a Hastelloy and stainless steel enclosure for optimum corrosion resistance, the PDCR 4000 is compact, rugged and able to operate reliably, even in the most hostile environments.

Large quantities of PDCR 4000 sensor "cores" are produced and held in stock. These are then selected and completed with pressure and electrical connections to meet individual customer requirements. This partially built core concept ensures flexibility of choice, while maintaining a short delivery. Additionally, every core is fully tested over its complete pressure and temperature range to ensure one hundred percent compliance.

The high performance PDCR 4000 is ideally suited to meet the demands of a wide range of applications, particularly in harsh operating environments where:

- accuracy
- stability
- reliability
- overpressure
- choice of specification

are important selection criteria, together with quick delivery.



Pressure Measurement Specification

Operating Pressure Ranges

PDCR 4000

1, 2 psi gauge
5, 10, 15, 20, 30, 50, 100, 200, 300, 500, and 900 psi gauge or absolute
1000, 2000, 3000, 5000, 7500, and 10,000 psi sealed gauge or absolute

PDCR 4100

1, 2, 5, 10, 15, 20, 25, 30, 50, 75, 100, 200, 300, and 500 psi differential

Other pressure units can be specified e.g. millibar, bar, kg/cm², kPa, etc.

Overpressure

The operating pressure range may be exceeded by the following multiples with negligible effect on calibration.

PDCR 4000

Gauge and absolute:

10 x for ranges 1 to 2 psi
6 x for range 5 psi
4 x for ranges 10 psi to 900 psi up to maximum of 2000 psi
2 x for range 1000 through 10,000 psi to a maximum of 15,000 psi

PDCR 4100

Differential (positive side):

10 x for ranges 1 and 2 psi
6 x for range 5 psi
4 x for ranges 10 to 300 psi
3 x for range 500 psi

Differential (negative side):

6 x for ranges 1, 2 psi
4 x for range 5 psi
2 x for ranges 10 to 75 psi
150 psi for ranges 100 to 500 psi

This overpressure capability can be further improved by selecting a range higher than required and operating with a lower output.

Pressure Containment

Gauge and differential (positive side):

12 x for ranges up to 5 psi
6 x for ranges 10 to 900 psi (3000 psi maximum)

Differential (negative side):

8 x for ranges up to 5 psi
4 x for ranges 10 to 500 psi
200 psi maximum for ranges 100 to 500 psi

Sealed gauge and absolute:

3000 psi for ranges up to 900 psi
20,000 psi for ranges 1000 psi and above

Pressure Media

Fluids compatible with Hastelloy C276 and stainless steel 316L.

Line Pressure

1000 psig maximum

Excitation Voltage

10 Volts at 5 mA nominal.

For pulse powered operation, the recommended power-on time is 10ms before sample.

Output is ratiometric to supply within the following limits:

1 V to 12 V for ranges up to 900 psi
5 V to 12 V for ranges 1000 psi and above

Output Voltage

(based on 10Vdc excitation)

50 mV for ranges 1, 2 and 5 psi
100 mV for 10 psi and above

Transducers with ranges up to 900 psi can be over ranged 2 x Full Scale to provide up to 200mV output. Linearity is slightly degraded but stability is improved.

For higher outputs up to 10 V refer to PMP 4000 series datasheet.

Common Mode Voltage

Typically +3.5 V to +9 V with respect to the –ve supply at 10 V excitation.

Output Impedance

2 k Ω nominal.

Load Impedance

Greater than 100 k Ω for quoted performance.

Performance Specification

Accuracy

Combined effects of Non-linearity, Hysteresis and Repeatability.

Standard : $\pm 0.08\%$ FS BSL maximum
Option (A) : $\pm 0.04\%$ FS BSL maximum

Higher accuracies can be selected from the core stock database.

Zero Offset & Span Setting

Zero: ± 3 mV maximum
Span : ± 10 mV maximum. Units of the same range are matched to closer than ± 3 mV.

Improved settings are available where interchangeability is critical.

Option (D): Consult factory

Stability

$\pm 0.1\%$ FS typically per annum

Long term stability is improved by using a lower pressure range in the overrange condition at a reduced excitation voltage.

Operating Temperature Range

-5° to +175°F standard
-65 to +250°F available

Temperature Effects

Standard: $\pm 0.3\%$ FS TEB over 32 to 122°F
 $\pm 1.0\%$ FS TEB over -5 to 175°F

For ranges up to 5 psi multiply x3

Improved Temperature Error Band (TEB) can be selected from the core stock database.

Acceleration Sensitivity

Typically 0.02% FS/g for 5 psi decreasing to 0.0003% FS/g for ranges above 900 psi, along the sensitive axis.

Mechanical Shock

1000g, 1ms half sine pulse in each of 3 mutually perpendicular axes will not affect performance.

Vibration

Response less than 0.05% FS/g at 30g peak 10Hz to 2kHz, limited by 12 mm double amplitude, (MIL-STD 810C Proc 514.2-2 Curve L)

Physical Specification

Pressure Connection

1 psi to 900 psi ranges

1/4" NPT Female
1/8" NPT Male w/Bulkhead Mount - standard
1/4" NPT Male
1/4" Tube Swagelok w/Bulkhead Mount
MS 33656-4 (1/4 AN)

Others available on request

1000 to 10,000 psi ranges: 1/4" NPT Female - standard

Adaptors available on request

Weight

4.5 oz nominal (1 to 900 psi)
6 oz nominal (1000 to 10,000 psi)
7 oz nominal for differential types

Electrical Connection

A wide range of cable and connector versions are available. Refer to ordering information and installation drawings overleaf.

Options

(A) Improved accuracy $\pm 0.04\%$ FS BSL.

(B) Internal Shunt Calibration (ranges up to 900 psi). Connecting an external link results in a positive span shift of 80% $\pm 5\%$ FS.

(Not available for PDCR 4X2X, PDCR 4X7X).

(C) Mating electrical connector (PDCR 4X6X).

(D) Improved zero and span settings (consult factory).

(E) Negative calibration

Accessories

A traceable calibration certificate with installation notes is supplied as standard.

Calibration Standards

Pressure transducers manufactured by Druck are calibrated against precision pressure calibration equipment which is traceable to the National Institute of Standards and Technology (NIST).

Druck is an ISO 9001 registered company.



Continuing development sometimes necessitates specification changes without notice.

PDCR 4000 Series

High Performance Millivolt Output Pressure Transducers



Ordering Information

Please state the following:
(1) Select model number

PDCR Basic type number

Code Pressure reference

- 40 Gauge, sealed gauge or absolute
- 41 Differential

Code Electrical Connection

- 0 Core (trimmed PCB)
- 1 6 Conductor vented cable
- 2 4 Conductor teflon cable
- 3 6 Conductor vented depth cable
- 6 6 Pin bayonet plug
- 7 Rotatable DIN plug and socket

Code Calibrated temperature range

- 0 32 to 122°F
- 1 -5 to +175°F

PDCR 40 2 1 Typical model number

- (2) Pressure range and units
- (3) Gauge, sealed gauge or absolute
- (4) Pressure connection
- (5) Cable length where applicable
- (6) Options (if required)

Related Products

Druck manufactures a wide range of pressure transducers and transmitters, associated digital indicators, barometers, and a complete range of precision process calibrators and controllers for the field, workshop and laboratory.



Pictured Left to right
DPI 610 Field Portable Pressure Calibrator
TRX-II Portable Documenting Process Calibrator
LPM 9000 Low Pressure Transducer
DPI 280 Digital Process Indicator

Installation drawings

Dimensions in inches.

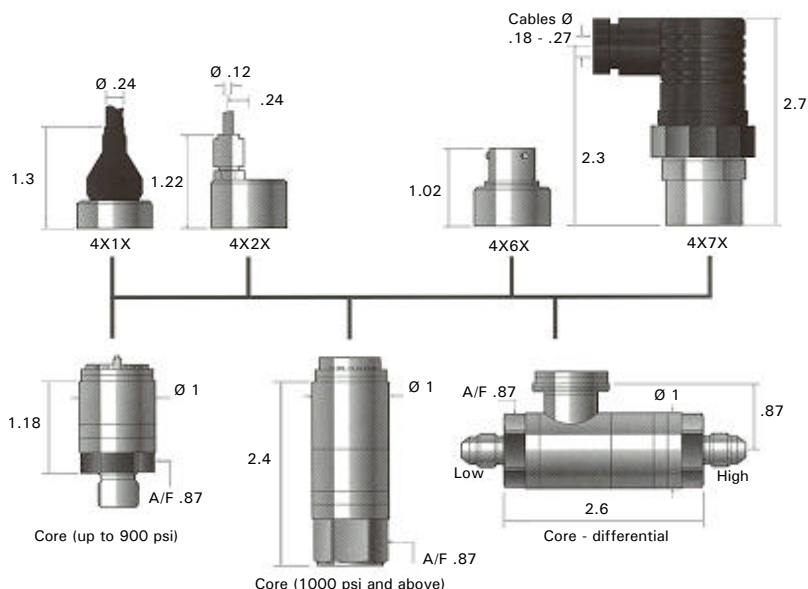

Electrical Connections					
Model Code	Supply + ve - ve		Output + ve - ve		R Cal
PDCR4X0X up to 900 psi	4	3	5	1	2
PDCR 4X0 up to 10k psi	4	5	3	2	n/a
PDCR 4X1X	Re	Wh	Ye	Bl	Or
PDCR 4X2X	Re	Bl	Ye	Gr	n/a
PDCR 4X6X	A	D	B	C	E
PDCR 4X7X	1	2	3	E	n/a

Re = Red conductor
Wh = White conductor
Ye = Yellow conductor
Bl = Blue conductor
Gr = Green conductor
Or = Orange conductor
Note: Shield and black conductor not connected to transducer body



Druck Incorporated

Representative :

Druck PDCR 4000

Distributor: ThermX Southwest 800-284-3769

www.thermx.com

USPDCR-4000